

Gravity, Torque, Centripetal Acceleration

* - means for regular physics only.

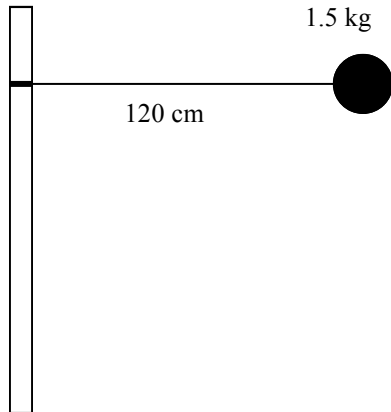

Centripetal Acceleration and Force

1. A ball is being spun around a pole on a pivot so the string doesn't shorten. Miraculously, it is absolutely horizontal to the floor as it moves thru the air. The ball completes 12 complete circles in 8.5 seconds.
 - A. Calculate how far it moves in one circle (the circumference), being sure to use meters.
 - B. Calculate the how far it travelled in 12 circles.
 - C. Calculate the tangential velocity (speed) of the ball.
 - D. Calculate the centripetal acceleration of the ball.
 - E. Calculate the tension in the rope.
2. A car turns a corner going 8 m/s. The corner has a radius of 30 meters.
 - A. Find the centripetal acceleration of the car.
 - B. If the car is 1200 kg, find the centripetal force necessary to turn the corner.
 - C. What gives the centripetal force to the car?

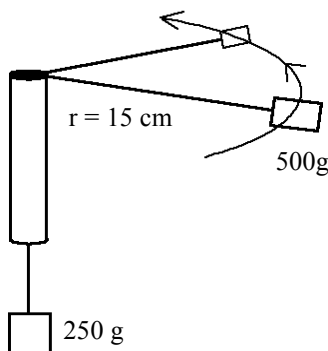

3. The graphic at the left shows a 500g mass being spun in a circle by a string attached to a 250g mass.
 - A. What do we call the force that keeps an object in a circle?
 - B. What gives the 500g mass this force?
 - C. Convert both masses to kilograms.
 - D. What is the weight of the 250g mass?
 - E. If the 250g mass is suspended in the air, what is the tension in the rope?
 - F. Since the two objects are connected by the same rope, how much tension is pulling on the 500g mass?
- E. What is the velocity of the 500g mass?
- The 500g mass then speeds up, moving around the circle faster. (*Hint: use the equation.*)
- F. Does the 500g mass need more or less tension to move faster?
 - G. Does the 250g mass move up or down?

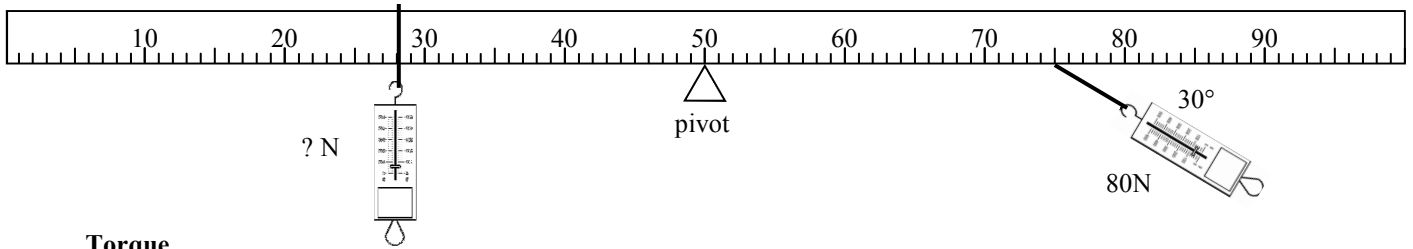

Torque

4. A 80 N force is applied to the lever at an angle of 30° at the position shown (*make the 80N perpendicular).
 - A. If the lever stays balanced, what is the magnitude of the left force?
 - B. Where would a force be attached to provide no torque?

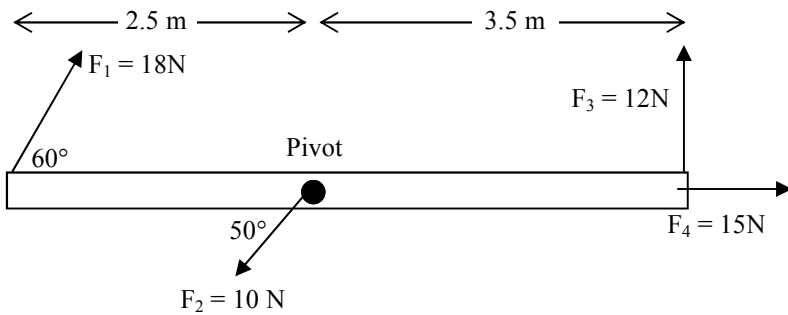

5. Use the diagram at the left to answer the following.
 - A. Which forces give negative torque?
 - B. Which forces give no torque?
 - C. Calculate each torque (*make perpendicular).
 - D. (*Honors*) Calculate the net torque on the lever.

Gravity

6. How does the gravity change if you double one of the masses and triple the distance between them?
7. A 45 kg object is 2.5 m from a 160 kg object.
 - A. Calculate the force of gravity between the objects.
 - B. What is the force of gravity of the earth on the 45kg object?
 - C. So, why is it that we don't feel the force of gravity from other objects around us?

8. A. Under the diagram, calculate both forces of gravity acting on object B. Be sure to draw the direction they are pointing.

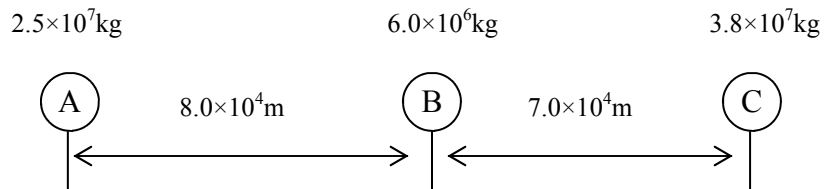

- B. What is the total force of gravity acting on object B?

Gravity, Torque, Centripetal Acceleration

* - means for regular physics only.

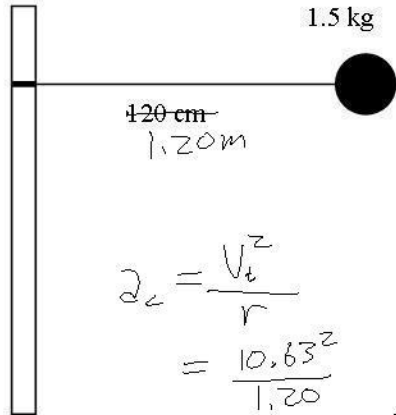

Centripetal Acceleration and Force

1. A ball is being spun around a pole on a pivot so the string doesn't shorten. Miraculously, it is absolutely horizontal to the floor as it moves thru the air. The ball completes 12 complete circles in 8.5 seconds.

A. Calculate how far it moves in one circle (the circumference), being sure to use meters.

$$C_{ir} = 2\pi r = 7.53 \text{ m}$$

B. Calculate the how far it travelled in 12 circles. $12(7.53) = 90.36 \text{ m}$

C. Calculate the tangential velocity (speed) of the ball.

$$S = \frac{D}{T} = \frac{90.36}{8.5} = 10.63 \text{ m/s}$$

D. Calculate the centripetal acceleration of the ball.

$$a_c = \frac{V_t^2}{r}$$

$$= \frac{10.63^2}{1.20}$$

$$= 94.16 \text{ m/s}^2$$

$$\Sigma F = ma$$

$$T = 1.5(94.16)$$

$$= 141.24 \text{ N}$$

E. Calculate the tension in the rope.

2. A car turns a corner going 8 m/s. The corner has a radius of 30 meters.

A. Find the centripetal acceleration of the car.

$$a_c = \frac{(V_t)^2}{r} = \frac{8^2}{30} = 2.13 \text{ m/s}^2$$

B. If the car is 1200 kg, find the centripetal force necessary to turn the corner. $F = ma = 1200(2.13) = 2556 \text{ N}$

C. What gives the centripetal force to the car?
 F_s (static friction)

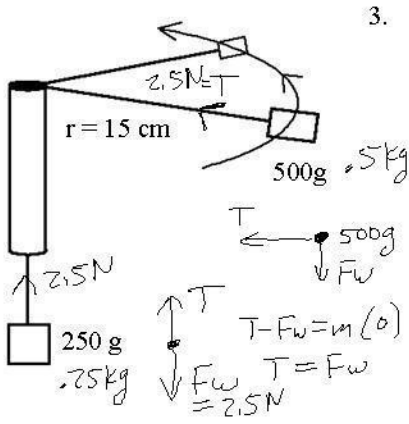

3. The graphic at the left shows a 500g mass being spun in a circle by a string attached to a 250g mass.

A. What do we call the force that keeps an object in a circle? centripetal

B. What gives the 500g mass this force? tension

C. Convert both masses to kilograms.

D. What is the weight of the 250g mass? 2.5 N

E. If the 250g mass is suspended in the air, what is the tension in the rope?

$$T - F_w = ma \quad T - 2.5 = .25(0) \quad T = 2.5 \text{ N}$$

F. Since the two objects are connected by the same rope, how much tension is pulling on the 500g mass?
2.5 N

E. What is the velocity of the 500g mass?

$$a = \frac{V_t^2}{r}$$

$$F = ma$$

$$F = m \frac{V_t^2}{r}$$

$$2.5 = .5 \frac{V_t^2}{.15}$$

$$S = \frac{V_t^2}{.15}$$

$$V_t^2 =$$

$$V_t = 8.66 \text{ m/s}$$

The 500g mass then speeds up, moving around the circle faster. (Hint: use the equation.)

F. Does the 500g mass need more or less tension to move faster?

G. Does the 250g mass move up or down?

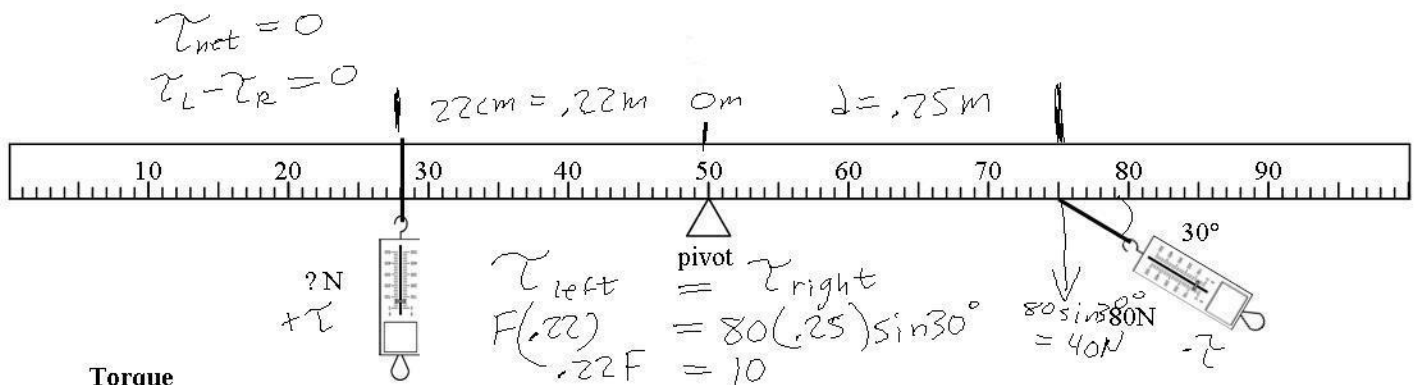

Torque

4. A 80 N force is applied to the lever at an angle of 30° at the position shown (*make the 80N perpendicular).
- A. ~~Where does the second force need to be attached to the lever~~ to keep the lever balanced?
how much is

$F = 45.45 \text{ N}$

- B. Where would a force be attached to provide no torque?

at pivot OR parall. to lever

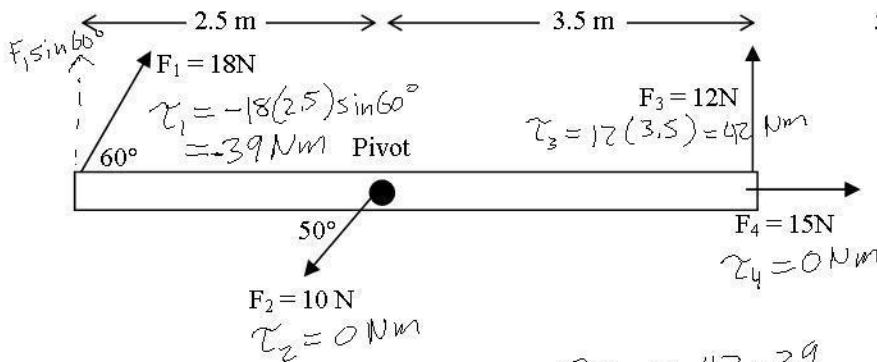

5. Use the diagram at the left to answer the following.

- A. Which forces give negative torque? F_1
- B. Which forces give no torque? $F_2 + F_4$
- C. Calculate each torque (*make perpendicular).
see diagram
- D. (Honors) Calculate the net torque on the lever.

$\tau_{net} = 42 - 39 = 3 \text{ Nm}$ ←

Gravity

6. How does the gravity change if you double one of the masses and triple the distance between them?

$F_g = G \frac{m_1 m_2}{r^2}$ $\frac{2}{3^2} = \frac{2}{9}$

7. A 45 kg object is 2.5 m from a 160 kg object.
- A. Calculate the force of gravity between the objects.

$F_g = G \frac{m_1 m_2}{r^2} = 6.673 \times 10^{-11} \frac{(45)(160)}{2.5^2} = 7.69 \times 10^{-8} \text{ N}$

- B. What is the force of gravity of the earth on the 45kg object? 450 N
- C. Why is it that we don't feel the force of gravity from other objects around us?
Force of weight due to the earth is so much bigger that we don't feel the other gravitational forces around us.

8. A. Under the diagram, calculate both forces of gravity acting on object B. Be sure to draw the direction they are pointing.

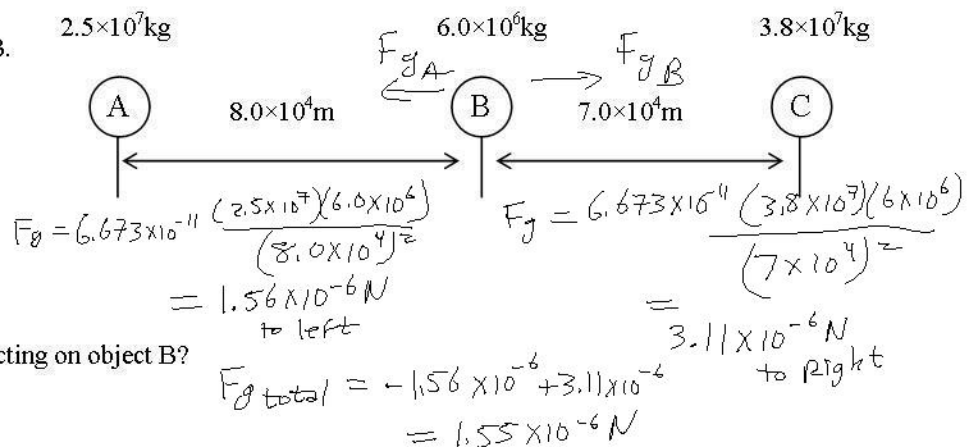

- B. What is the total force of gravity acting on object B?